

controalseal.nl



Non Contact Rising Stem Ball Valve

RSBV



controalseal

VALVE TECHNOLOGY

On/Off metal-to-metal ball valve for long life under extreme conditions

Size	1" ~ 36
Bore	Reduced or full (piggable)
Pressure	150# ~ 2500#
Temperature	-196°C ~ 538°C
Connections	Wide choice on request
Materials	Wide choice on request

Applications

Molecular Sieve:

For long life and easy maintenance

Shell Prelude, FPSO Tartaruga Verde, Ichthys Onshore LNG, Jazan Refinery, Yanbu Refinery

Hydrogen service (NACE):

For reliability under high pressure condition

Porvoo Refinery, Jubail Refinery, Jinling Refinery

Sand and slurry applications:

For durable sealing surfaces

Grangemouth, Hammerfest LNG Plant

Emergency blow/shut down service:

For fast opening and closing

Bayu Undan, Kristin Offshore Platform

Cryogenic service:

For smooth operation under extreme temperature

HMC Polymers PP Plant, ColdBox Platform

Petrochemical:

For long life and easy maintenance

Schkopau Germany, Saudi Kayan HDPE Project

Hot oil installations:

For smooth operation under extreme temperature

Djeno Moho Bilondo Congo, Sakhalin Russian Federation

Steam service:

Fields Girasol Y Moriche Colombia

Recognized by industry leaders



ExxonMobil

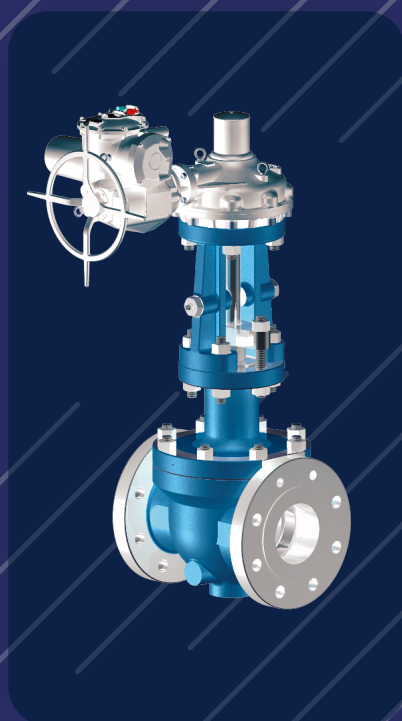

Certificates



Design

Design	API 6D, ASME B16.34
Face to Face dimensions	API 6D, ASME B16.10, B16.47
Flanges	ASME B16.5, B16.25
Fire Safe	ISO 10497, API 6FA, BS 6755
Fugitive Emission	ISO 15848, TÜV, Shell MESC SPE 77-312
Testing	API 598
Marking	CE, MSS-SP-25
Topworks	ISO 5210

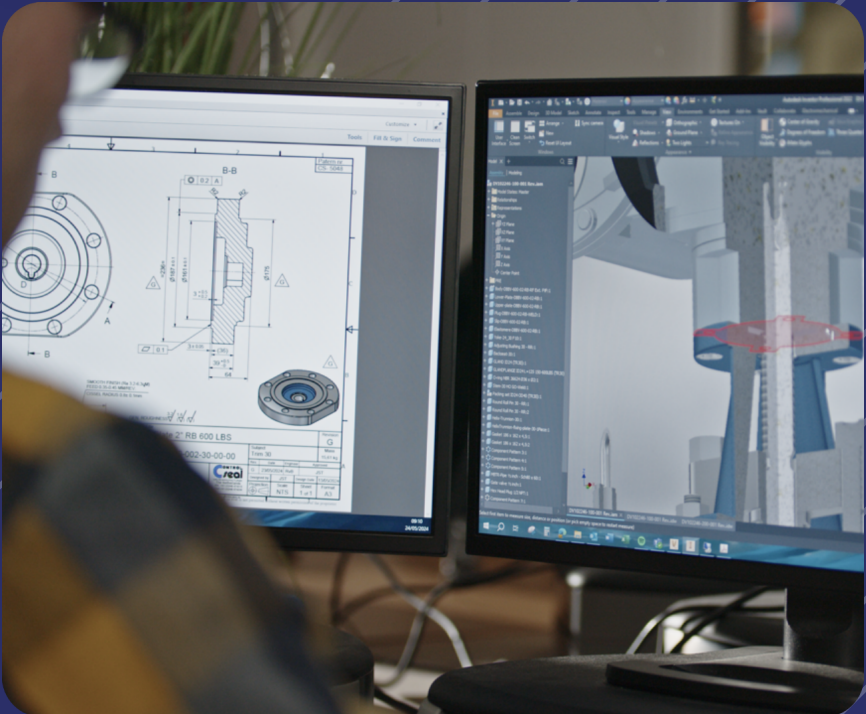

Contact Us

info@controlseal.nl
sales@controlseal.nl
service@controlseal.nl
Farmsumerweg 43
9902 BL Appingedam
The Netherlands
+31 596 652 222

